



ಜನತಾ ಶಿಕ್ಷಣ ಸಮಿತಿಯ

Estd. : 1956

ಕೆ. ಎಚ್. ಕಬ್ಬೂರ ಕಾಂತ್ರಿಕ ಶಿಕ್ಷಣ ಸಂಸ್ಥೆ

ಸರ್ಕಾರಿ ಅನುದಾನಿತ ಹಾಗೂ ಎಐಸಿಟಿಇ-ನವದೆಹಲಿಯಿಂದ ಮಾನ್ಯತೆ ಪಡೆದ ಪಾಲಿಟೆಕ್ನಿಕ್

K. H. KABBUR INSTITUTE OF ENGINEERING 202

Govt. Aided and AICTE-New Delhi Approved Polytechnic

Vidyagiri, Dharwad-580 004. KARNATAKA

Off. Ph : 0836-2468654, email : khkie202@yahoo.com khkie202@gmail.com Website : www.khkie.co.in

Current Application Number ~~1-43664796389~~ and Permanent Institution ID : ~~1-475384387~~

Ref :

KHKIE/DD/AICTE-Essential/2024/18

Academic Year: 2024-25

Date :

Dated: 03-04-2024

CERTIFICATE

DETAILS OF BACK UP POWER OF ALL DEPARTMENTS			
DEPARTMENT	UPS	CAPACITY IN KVA	BATTERIES
AT	1	5	6
CE	2	5+3=8	6
CP	2	5+3=8	9
CS	3	5KVA EACH=15	18
EC	0	-	-
EE	1	5	4
MC	2	5+3=8	12
ME	2	3KVA EACH=6	8
SCIENCE	-	-	-
OFFICE	2	3 KVA EACH=6	2
LANG-1	-	-	-
LANG-2	-	-	-
LIBRARY	2	3 KVA EACH=6	6

Certified the institution is having the Power Supply Backup facilities as projected in the above table with Backup of 62 kVA

The above document is available on the institution website

hyperlink: <http://www.khkie.co.in/Desirable.html>

Date:

Vinodini
Principal

J.S.S.'s K. H. Kabbur Institute of Engg.
DHARWAD - 580 004.



**UPS BACKUP DIAGRAM
KHKIE DHARWAD**

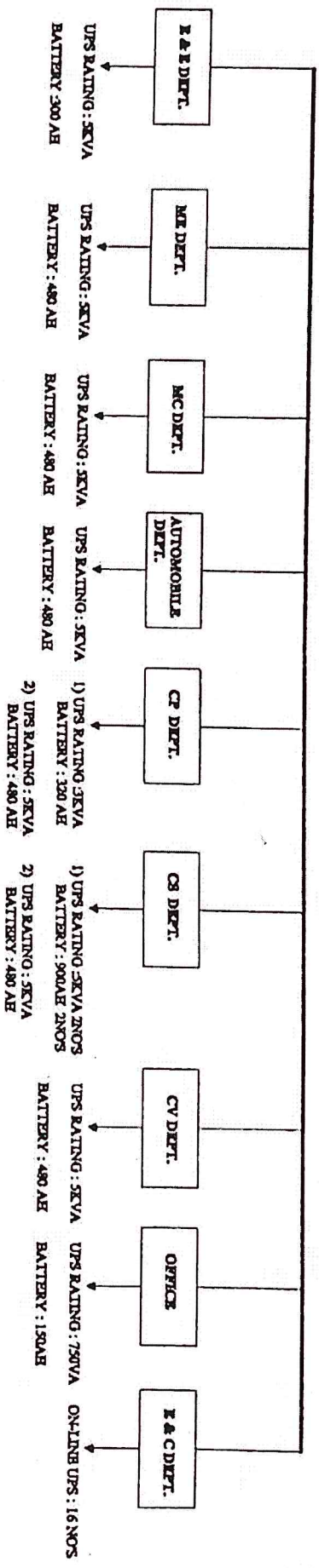

The Head of Electrical & Electronic
 K.H.K. Inst. of E.
 Vidyanagar, Dharwad.

PRINCIPAL
 J.S.S.'s K.H. Kabbur Institute of Engg
 DHARWAD - 580 004